

FOCUS ON

# OUTDOOR POWER EQUIPMENT

TECHLINE® – When the going  
gets tough, the tough get going

[www.linak.com/techline](http://www.linak.com/techline)

# Outdoor Power Equipment

With focus on improved ergonomics for the end-user, as well as increased productivity, many manual work processes are today replaced by electric movement in highly automated and innovative machines. This is exactly the kind of movement that has been the focus for more than 25 years at LINAK.

In this focus folder, we target manufacturers of powered lawn and garden maintenance products, components and attachment supplies, as well as industry related services – in general called “Outdoor Power Equipment”.

So what can LINAK do for outdoor power equipment manufacturers?

- Supply of reliable products designed for harsh and rugged conditions like vibration, dust, and moist
- One supplier of complete actuator systems for almost any needs
- Maintenance free products with long lifetime
- High degree of flexibility
- Close co-operation with our application engineers, represented in more than 30 countries
- A worldwide network of aftersales service

Choose LINAK for...

## A Knowledgeable Partnership

Multilevel cooperation with our customers is extremely important, for the benefit of both LINAK and customer. Partnership is the driving force behind R&D, aftersales, logistics, manufacturing and marketing.



### Extensive product range

LINAK's product range is one of the most flexible and extensive in the business. We cover every need from the small, light and compact LA12 to the newest, toughest and powerful LA36.

All actuators within the LINAK TECHLINE® business area have one thing in common. They are built to work in those rough spots, where most electric equipment gives up. The actuators are tested according to the highest standards, and can be delivered in protection classes up to IP66 – water and dust proof.

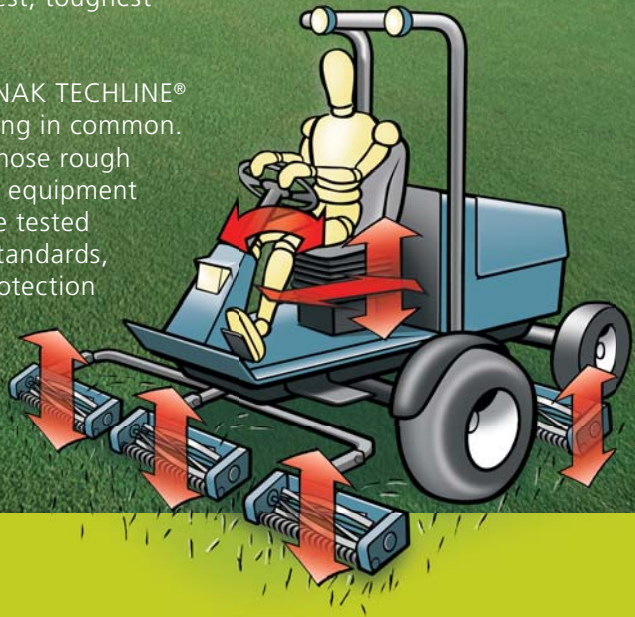

## APPLICATION FOR LAWN AND GARDEN EQUIPMENT

### Utility vehicles

Easy and steady electrical operation of the dump bed is very convenient even on these smaller vehicles.



### Electrical power wagons

Convenient where it's difficult to move heavy loads, a strong alternative to wheelbarrows



Choose LINAK for...

## Robust and powerful

LINAK products are reliable products, made to last! High quality is the trademark of LINAK, and an element of the highest importance to us.





### Dump bed trailer

Electrical tilting of the trailer, convenient if heavy loaded.

### Salt spreader with front sweeper

Opening and closing for the salt outlet, and lifting the sweeper.  
Adjustment of snowplow etc.

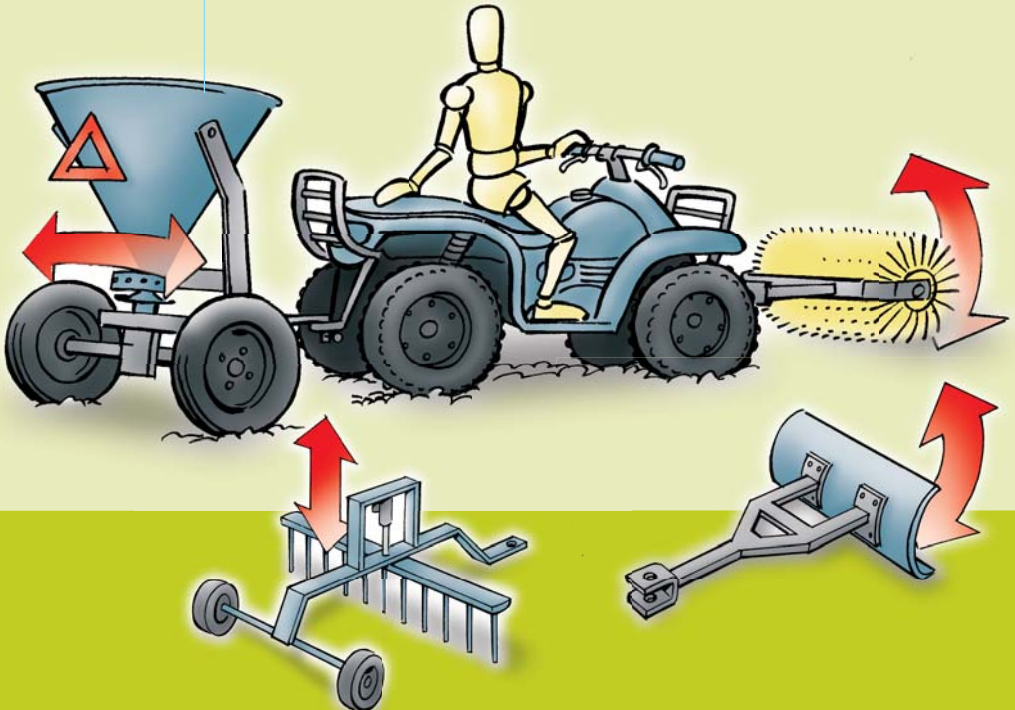

## APPLICATION FOR LAWN AND GARDEN EQUIPMENT



### Lawn tractors

With electrically emptying features,  
and adjustment of the cutter deck

## Choose LINAK for... Global Presence

LINAK has a well-developed sales and service organisation in Europe, America, Asia and Australia. Therefore, we can assist you and your customers locally, under the global sales concept idea:  
Be global, act local



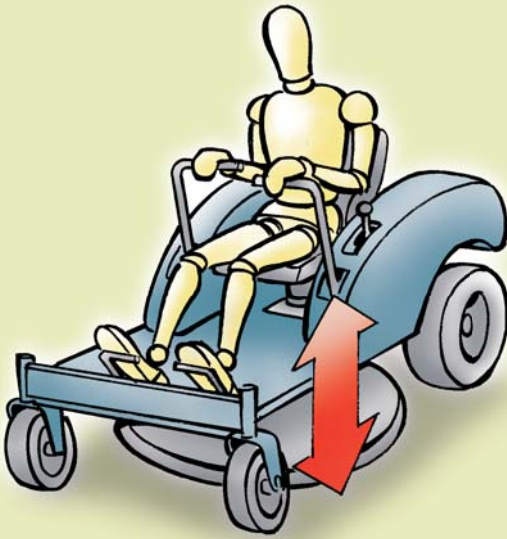

### Lawn movers

High performance series of ride-on lawn mowers has electrically adjustable cutter decks.

These rugged and durable machines set high demands for electrical actuation.

### Lawn movers

Adjustment of the cutter deck.  
Individually adjustment of the cutter blades

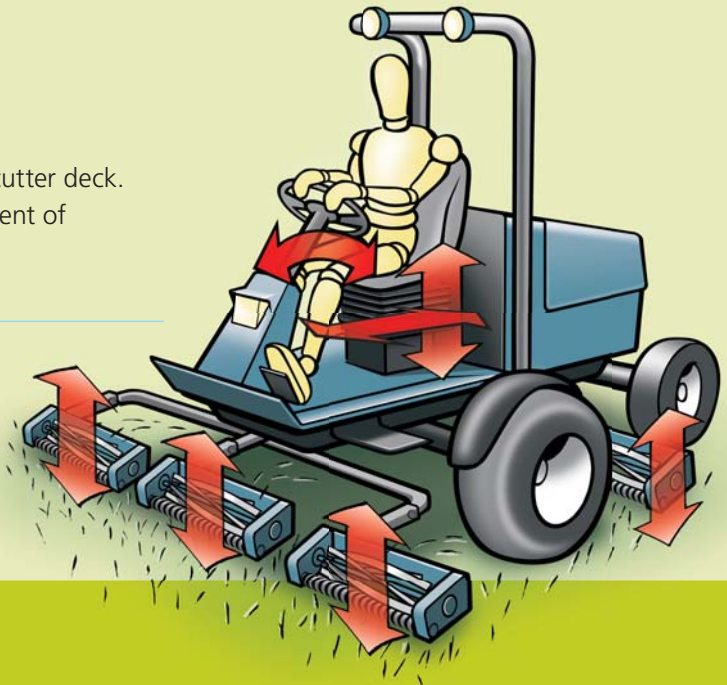

# ACTUATORS FOR OUTDOOR POWER EQUIPMENT

## DURABLE AND RELIABLE

The LA36 has been developed for harsh conditions and is the most robust actuator in our program.

Trust:	Max 10,000 N
Speed:	15-160 mm/sec
Stroke length:	50-999 mm
Duty cycles:	up to 20%
Voltage:	12, 24 or 36 V DC
End-stops:	Slip clutch or built in limit switches

- Solid metal construction
- Hand crank for manual operation
- Salt and chemical tested
- High pressure cleaner-proof

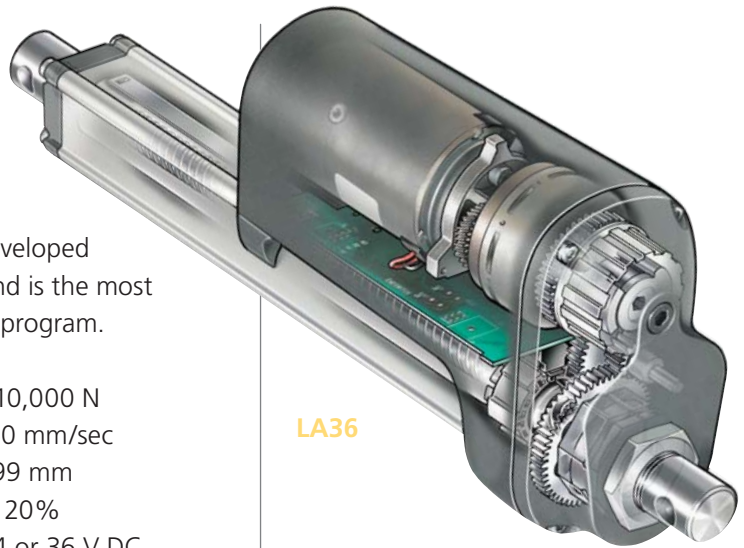

LA36

Scope of application:

- Utility vehicle dump bed
- Engine hatch lifts
- Mower deck adjustments
- Snowplows
- ATV attachments
- Agriculture applications

## Choose LINAK for... Knowledge

At LINAK we focus on our core competence – production of actuator systems. But we do more than this. We want to understand our customer's business by focusing on the individual customer's needs, market intelligence and application know-how.



## FLEXIBLE AND POWERFUL

- Max thrust up to 6,000 N in push and up to 4,000 N in pull
- Heavy-duty aluminium housing for harsh conditions
- Protection class IP 66 dynamic, IP 69K static
- Stroke up to 600 mm
- Easy to use interface – with integrated power electronics for direct connection to control system
- Potential free limit switches as an option
- Hall sensors or potentiometer for relative or absolute feedback, regardless of the stroke length
- Built-in limit switches and brake
- Voltage 12 or 24 V DC

**The LA35 actuator is a new member of the TECHLINE® family. It is characterised by its robust design allowing the actuators to be used in harsh and extreme conditions. The LA35 actuator is designed to meet the challenge, based on the philosophy that it must be able to operate on off-highway equipment such as agriculture, forestry and construction machines.**



LA35

## LIGHT AND COMPACT



**LA12**

The LA12 is ideal for different kinds of outdoor mobile applications, where small adjustments are required.

Trust:	Max 750 N
Speed:	5-50 mm/sec
Stroke length:	40-130 mm
Duty cycles:	up to 100%
Voltage:	12/24 V DC
End-stops:	Built in limit switches

- Compact and lightweight
- Chemical and rust resistant
- Fiberglass reinforced construction

Scope of application:

- Throttle adjustment
- PTO
- Grass catcher door
- Spreader adjustments

## RUGGED



**LA30**

The LA30 is a very versatile actuator for industrial and outdoor applications where strength and speed are essential.

Trust:	Max 6,000 N
Speed:	10-65 mm/sec
Stroke length:	50-600 mm
Voltage:	12, 24 or 36 V DC
End-stops:	Limit switches or current cut-off

- Solid metal construction
- Compact and powerful
- Suitable for harsh conditions

Scope of application:

- Engine hatch lifts
- Spreader adjustments
- ATV attachments
- Agriculture applications

## Choose LINAK for... Innovation

Innovation is the keyword to the success of LINAK. Today LINAK is the company within manufacturing of linear actuator systems to bring most new products to the market and to hold most technology-based patents. Therefore, we can always offer the newest technology, giving our customers a competitive edge.



# ACCESSORIES

## COMPLETE CONTROL

- Variable power supply 12-36 V DC
- Overload protection - adjustable current limit 1-20 A
- Adjustable soft start and stop
- Several versions for different applications
- Integrated brake

(\*)



**MOTOR CONTROLLER**  
TR-EM-208

## COMPLETE CONTROL



**PARALLEL CONTROLLER**

## EASY OPERATION

- For all actuators with limit switches
- Easy operation of actuators without use of further electronics
- IP 66 for outdoor use
- Easy to install
- Tested with an LA36 12 V DC for 50,000 operations

(\*)



**ROCKER SWITCH**

- Synchronized parallel control for 2 actuators
- Operates with pulse feedback (Hall or Reed)
- Current and temperature limited
- Soft start/stop
- Adjustable drive speed
- Accurate repeatability
- Easy setting via serial interface

(\*)

(\*) "The specified product is a third party product that is produced by third party and distributed by LINAK as a supplement to LINAK's existing product range. It is the responsibility of the product user to determine the suitability of the product for a specific application. LINAK will at point of delivery replace/repair defective products covered by the warranty if promptly returned to LINAK."

## GO ELECTRIC AND SPOT THE DIFFERENCE

When lifts up to 10,000 N are needed the electric actuator carries out the same job as the hydraulic system while providing significant benefits such as lower costs, easier to install, less weak

points and advantages when it comes to integration with control systems. Further more you can eliminate the risk of leaking oil when you go electric.

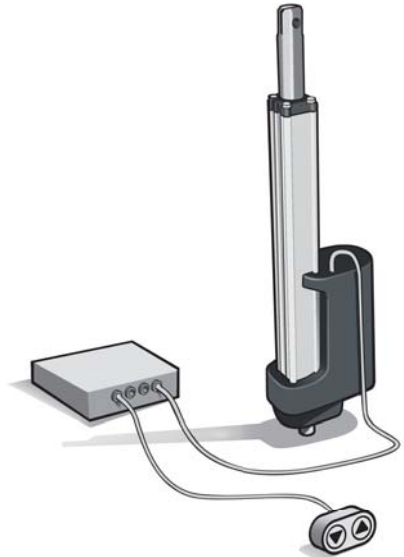
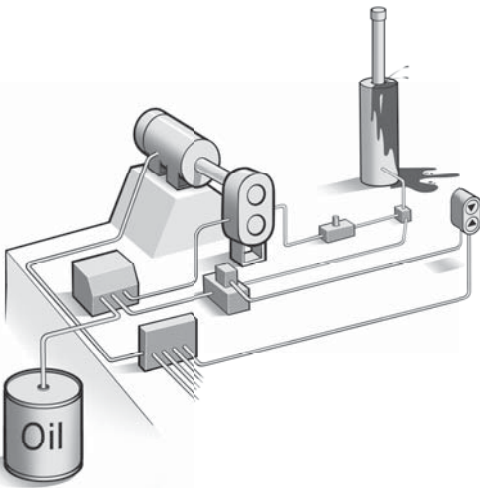

To build comfort into your machinery, make sure your applications are LINAK powered

## Choose LINAK for... World class operation

The LEAN philosophy permeates our entire production and way of thinking. For the customers it means that we deliver the right products, in the right quality, on time - at a competitive price.



## LA36 TESTING

Our products undergo thorough climatic, electrical and mechanical testing.



### CLIMATIC TESTING:

- Extreme Temperatures
- Rapid Temperature Changes
- Salt Spray
- Chemicals



### ELECTRICAL TESTING:

- Power Supply
- Power & Signal Cables
- Control Signals
- Electrical Immunity



### MECHANICAL TESTING:

- Vibration
- Shock
- Bump



As technology advances, LINAK will continue to develop products that improve the quality of people's lives and their working environment.

## OTHER CAPABILITIES

### TECHLINE® - FOR HARSH CONDITIONS

The TECHLINE® systems ease the load and make work easier. The remarkably wide product range offers something for any imaginable type of movement i.e. in industrial and agricultural machinery. With these actuators you can easily reach inaccessible places, open or close sun blinds and roof windows, regulate ventilators, close gates automatically – and save yourself exertion.

- For harsh conditions
- High speeds
- Strong forces
- Long lifetime
- No maintenance

### Stationary applications

Linear actuators make it possible to easily and economically adjust various functions in a wide number of stationary applications. LINAK TECHLINE® solutions can improve several facets of your company's working environment including ergonomic lifting, cost-effective automation, and ventilation.

Our comprehensive product programme can be tailored to match your specific needs. LINAK TECHLINE® solutions allow you to adapt your workplace to your workers rather than the other way round.

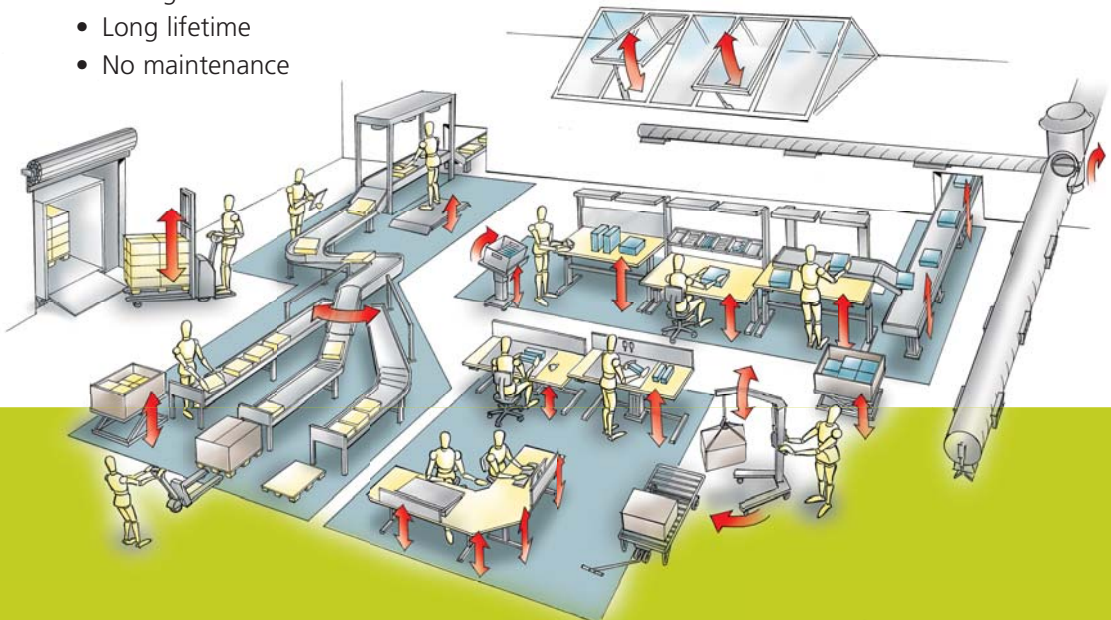

## Mobile applications

Linear actuators from LINAK can be used for thousands of different applications. We offer big advantages compared to other linear movements in mobile equipment. Please contact your local LINAK office who has extensive experience in integrating our products into different applications.

When LINAK develops and produces products, quality is the keyword for our employees. LINAK constantly strives to improve the quality and to reduce the risk of faults, which contributes to the fact that our customers experience LINAK as a supplier of high-quality products.

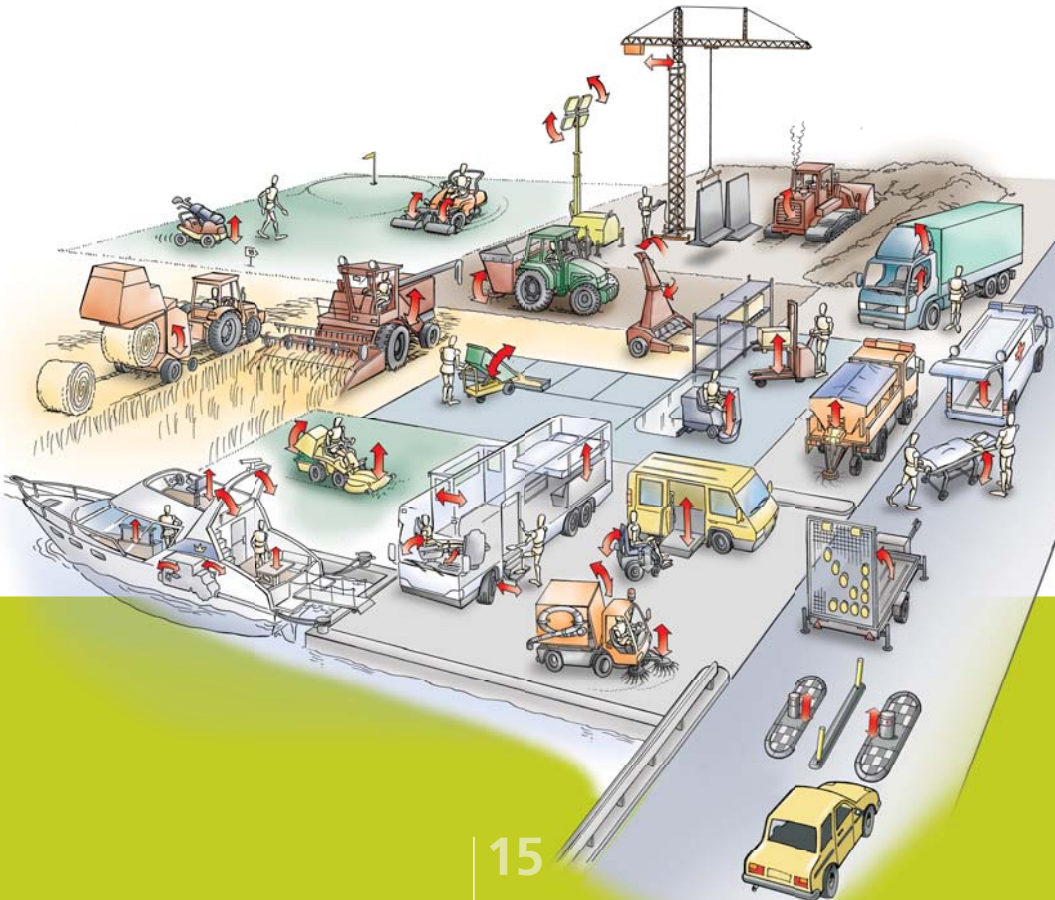

## LINEAR ACTUATOR TECHNOLOGY

**LINAK - many years of experience from the industry**

LINAK has over 25 years' experience as a supplier of linear movement for a broad selection of mobile and stationary applications in the industrial sector.

Application examples are automation of machine plants, adjustment of agricultural equipment, regulation of roof light windows, ventilation systems, combine harvesters, assembly lines, kettles, valves, and throttles. In brief, any purpose in the industry where a linear movement is required and where LINAK TECHLINE® can be used to facilitate working operations and maintenance.

**TERMS OF USE**

The user is responsible for determining the suitability of LINAK products for a specific application. LINAK takes great care in providing accurate and up-to-date information on its products. However, due to continuous development in order to improve its products, LINAK products are subject to frequent modifications and changes without prior notice. Therefore, LINAK cannot guarantee the correct and actual status of said information on its products. While LINAK uses its best efforts to fulfil orders, LINAK cannot, for the same reasons as mentioned above, guarantee the availability of any particular product. Therefore, LINAK reserves the right to discontinue the sale of any product displayed on its website or listed in its catalogues or other written material drawn up by LINAK.

All sales are subject to the Standard Terms of Sale and Delivery for LINAK. For a copy hereof, please contact LINAK.

[www.linak.com/techline](http://www.linak.com/techline)



WE IMPROVE YOUR LIFE