

# Steering housing

UM DANDIA™ tooling solutions for the automotive industry

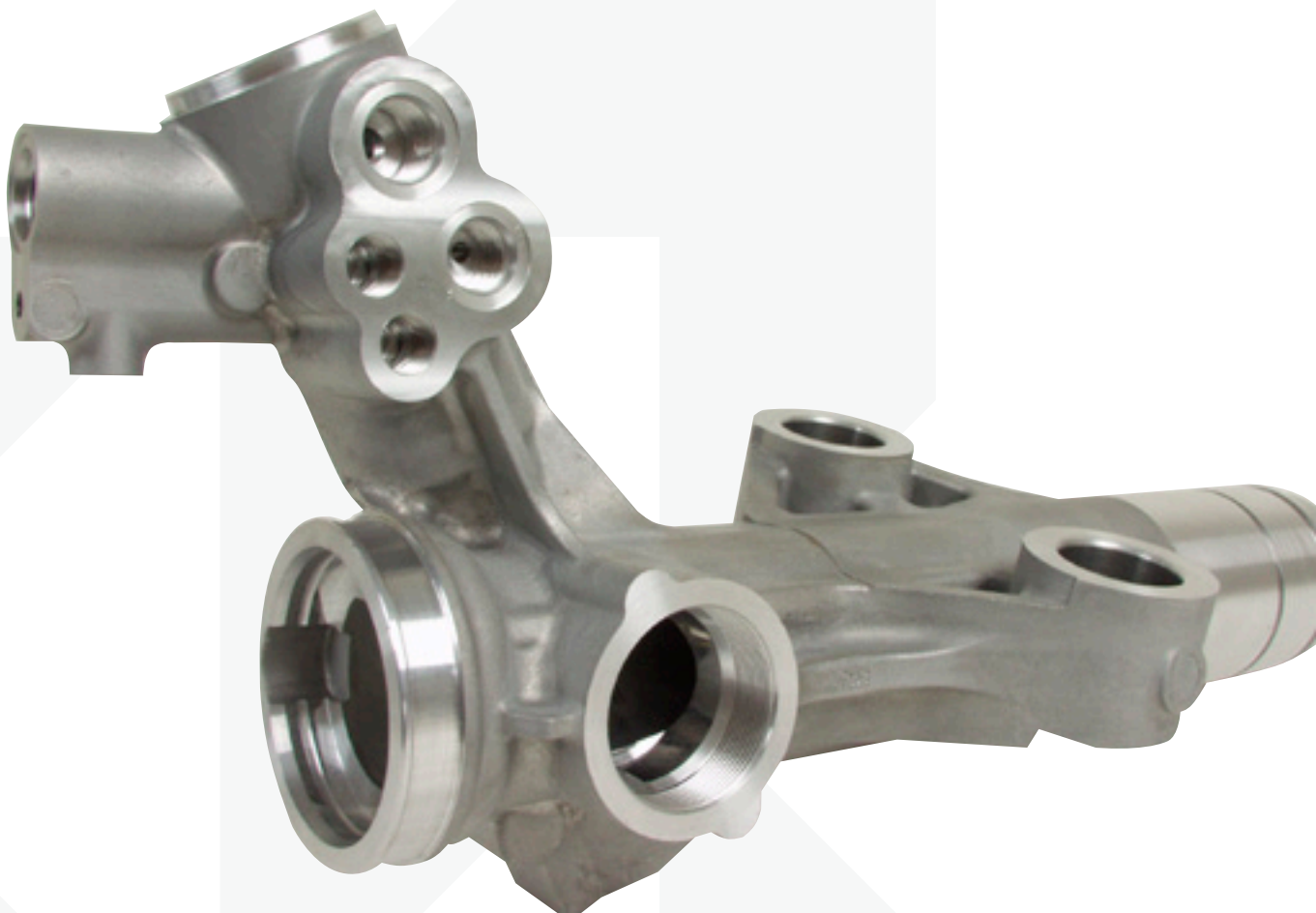
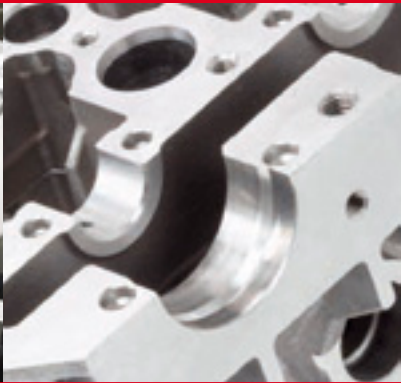

# KYOCERA UNIMERCO - YOUR INNOVATIVE PARTNER

KYOCERA UNIMERCO specializes in the manufacture of high performance PCD tooling, designed according to customer requirements. Some of the benefits of working together with us are:

## Optimization support

We do not just deliver tools. Our highly qualified tooling technicians have in-depth knowledge of automotive applications and each problem is analyzed thoroughly to come up with the best possible solution for you. In other words, we take complete care of your tool performance and ensure that you get the expected output.

## Delivery time

As a rule, Unimerco is able to deliver PCD tools in 6-8 weeks. In most cases, Unimerco will deliver you a design concept for the PCD tooling solution for review. And of course if you require it, we are able to make in-house tests, based on an hourly payment. The result will be documented in a report for you. Thereby we secure that our tools are delivered "ready-to-use".

## Not only regrinding but RE•NEW®

All tools are developed and manufactured utilizing the latest technology. And we regrind your tools with the same concern that we use to manufacture new tools. Original tool geometries are secured in our RE•NEW® process. We also RE•NEW® other tool brands with very good results - often better than when you received the tool as new.

## 100% repeatability

Due to a unique internally developed norm system and a very advanced drawing database, we are able to continuously deliver tools with the exact same geometries throughout all future deliveries, regardless in which KYOCERA UNIMERCO manufacturing facility your tools are being produced.

We look forward to your inquiry for a customized PCD tooling solution.

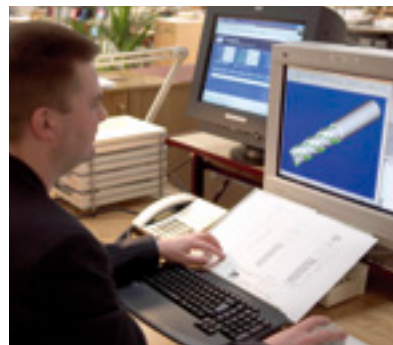

# UM DANDIA™ PCD TOOLS - STEERING HOUSING

We have in-depth knowledge of machining aluminum parts. Our tool package for steering housing components provides you with the following benefits:

## One shot tools

The result of extensive research and development activities is the “one shot” solution for many of the machining operations on steering housing components. The “one shot” solution makes the roughing pass tool redundant and a further benefit is reduced machining time. This solution has turned out to be very successful in a number of production environments.

## Combination tools

Like with roughing and finishing tools, a number of other tool designs have been developed in order to combine several operations in one tool. This is possible for many operations – like milling/reaming and reaming/grooving.

## Fewer tools needed

The combination of our “one shot” and “combination tool” approach has led to a reduction in the number of tools needed. In fact, with the tooling solution from KYOCERA UNIMERCO, you will probably need less than half the tools suggested by our competitors. Less tooling means shorter cycle time and higher productivity.

## Surface finish

With our tooling package, we have also achieved excellent surface finish results and great Cp and Cpk values. In some applications, we were asked by customers to generate a specified surface on some features. This meant that the surface finish had to be between certain values. This was achieved with a completely new tool design, where you can actually “dial in” the surface finish.

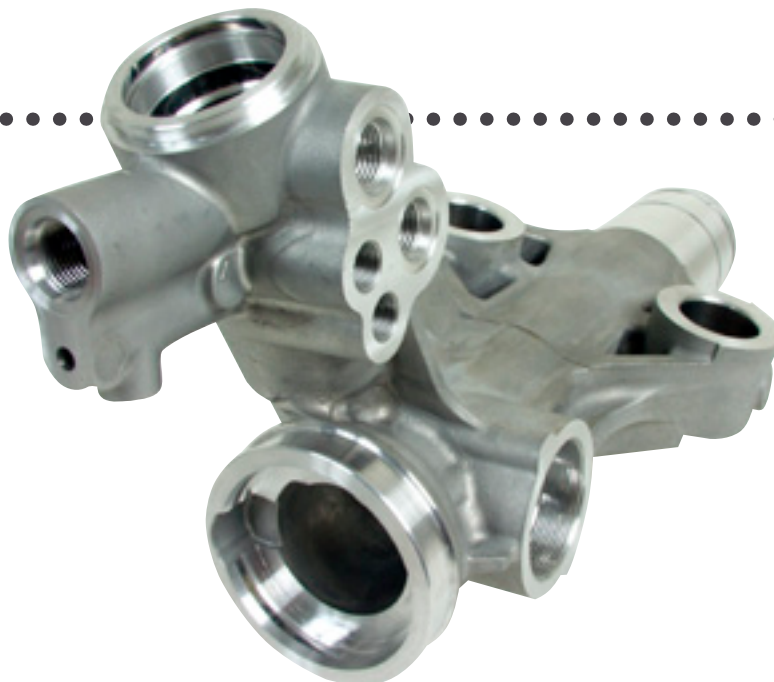

# STEERING HOUSING - TOOL PACKAGE

## SPIKE MOUNT

① n = 3000 RPM  
fn = 0,3 mm/rev.

② n = 3000 RPM  
fn = 0,3 mm/rev.

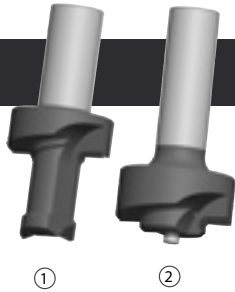

①

②

## COUNTER BORE OD

① n = 3000 RPM  
fn = 0,3 mm/rev.

n = 4200 RPM  
fn = 0,3 mm/rev.

②

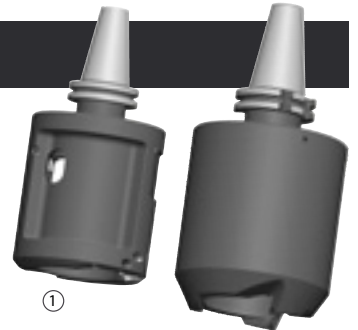

①

②

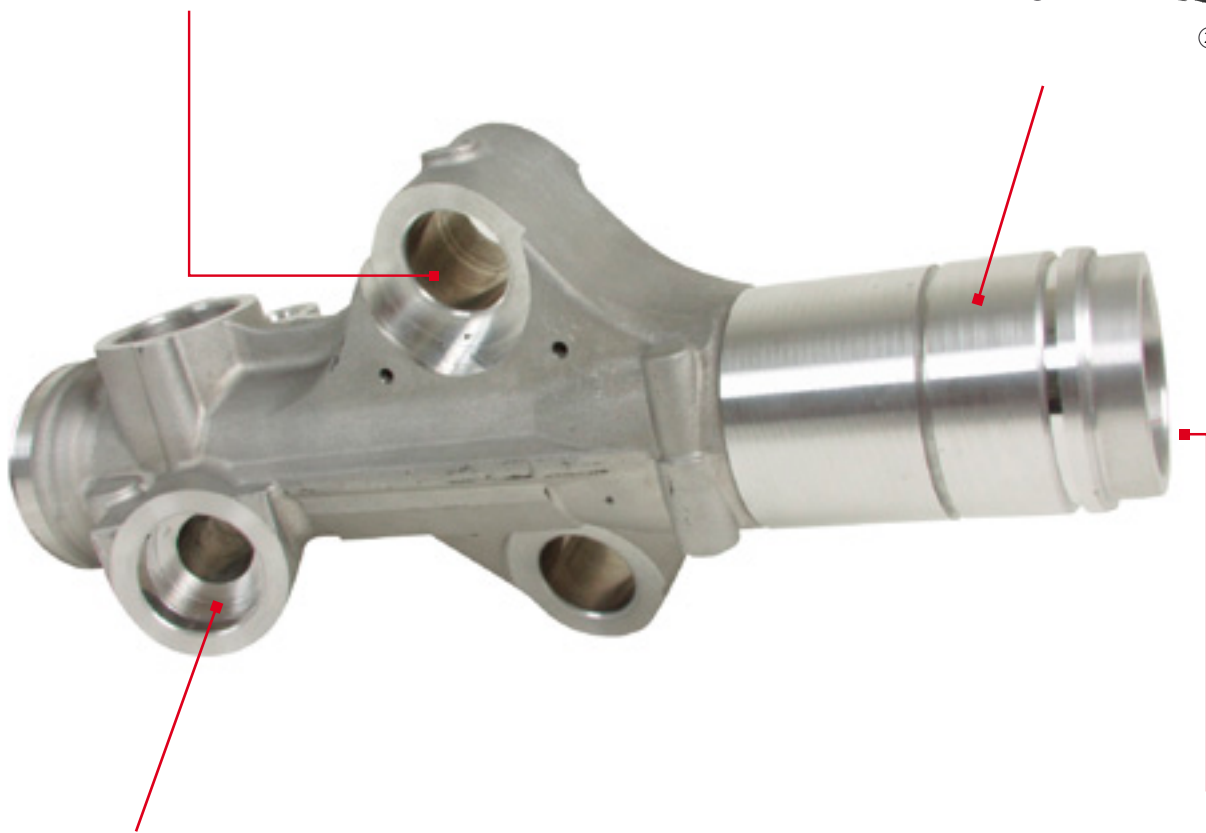

## PINION BORE

① n = 3000 RPM  
fn = 0,3 mm/rev.

② n = 3000 RPM  
fn = 0,3 mm/rev.



①

②

## COUNTER BORE

OD ① n = 6000 RPM  
fn = 0,4 mm/rev.

ID ② n = 3000 RPM  
fn = 0,3 mm/rev.

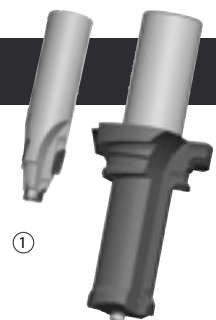

①

②

### VAPS PORT

- ① n1 = 12000 RPM  
fn = 0,2 mm/rev.
- n2 = 6000 RPM  
fn = 0,2 mm/rev.
- ② n = 10000 RPM  
fn = 0,2 mm/rev.
- ③ n = 6000 RPM  
fn = 0,3 mm/rev.
- ④ n = 6000 RPM  
fn = 0,2 mm/rev.

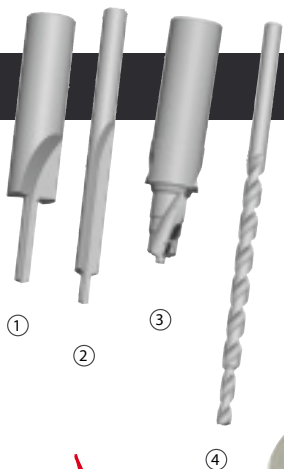

### VALVE BORE

- OD ① n = 6000 RPM  
fn = 0,4 mm/rev.
- ID ② n = 1000 RPM  
fn = 0,3 mm/rev.

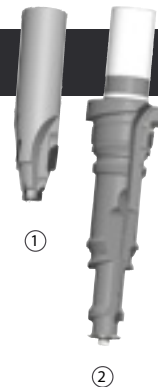

### CLUSTER FACE

- ① n = 6000 RPM  
fn = 0,3 mm/rev.
- ② n = 6000 RPM  
fn = 0,3 mm/rev.  
n = 6000 RPM  
fn = 0,3 mm/rev.
- ③ n = 6000 RPM  
fn = 0,3 mm/rev.

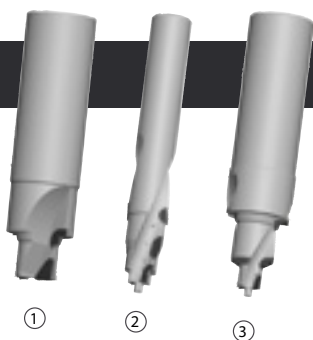

### YOKE BORE

- n = 3000 RPM  
fn = 0,3 mm/rev.



### RACK/BOOT

- ① n = 1200 RPM  
fn = 0,05 mm/rev.
- ② n = 3000 RPM  
fn = 0,3 mm/rev.

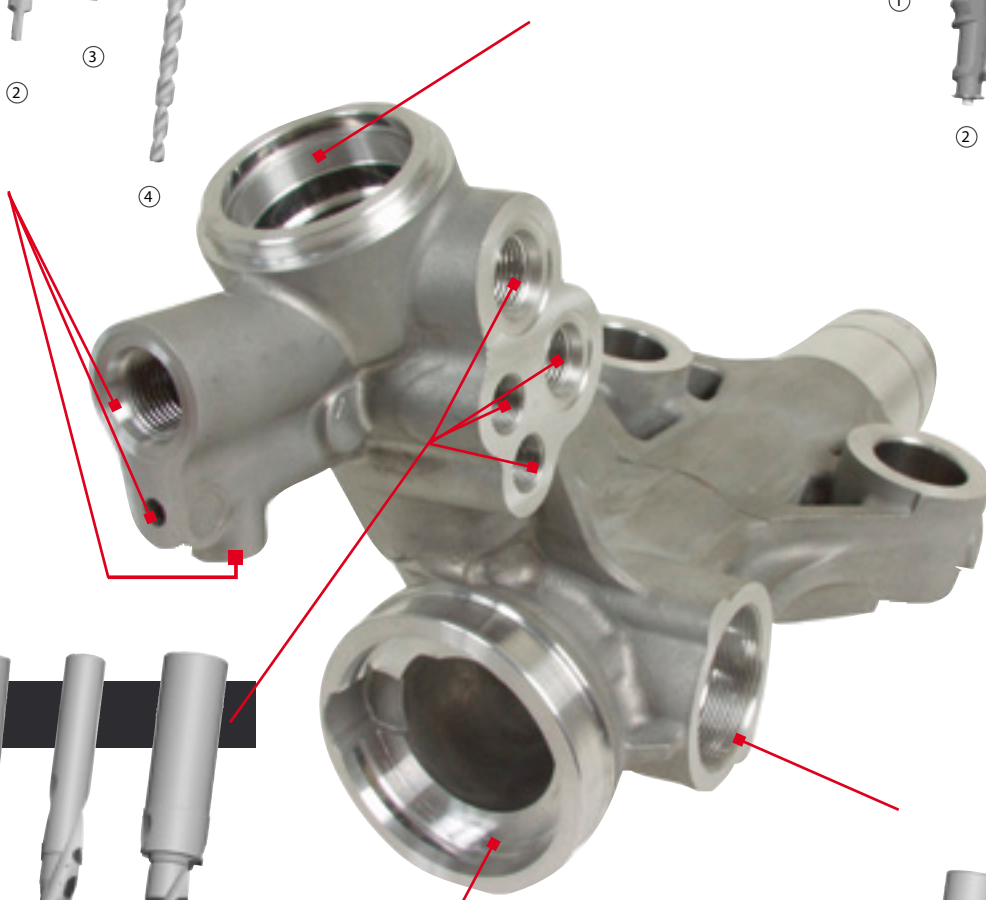
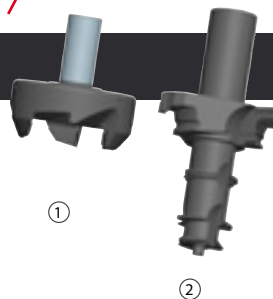

# OPTIMIZATION EXAMPLES

## DESIGN CONCEPT: Combination Tool - Mill & Ream

---

Yoke Bore Reamer + Cluster Face Mill  
One tool, two distinctly different operations!

This area designed to finish ream + Spotface the Yoke Bore, all in one pass

End teeth specially designed so tool can be used to mill all flat surfaces

Cutting data  
Reaming: 3000 rpm, 0.3 mm/rev.  
Milling: 6000 rpm, 0.4 mm/rev.

Center-cutting geometry allows tool to cut through any flashing left from casting process in the Yoke Bore

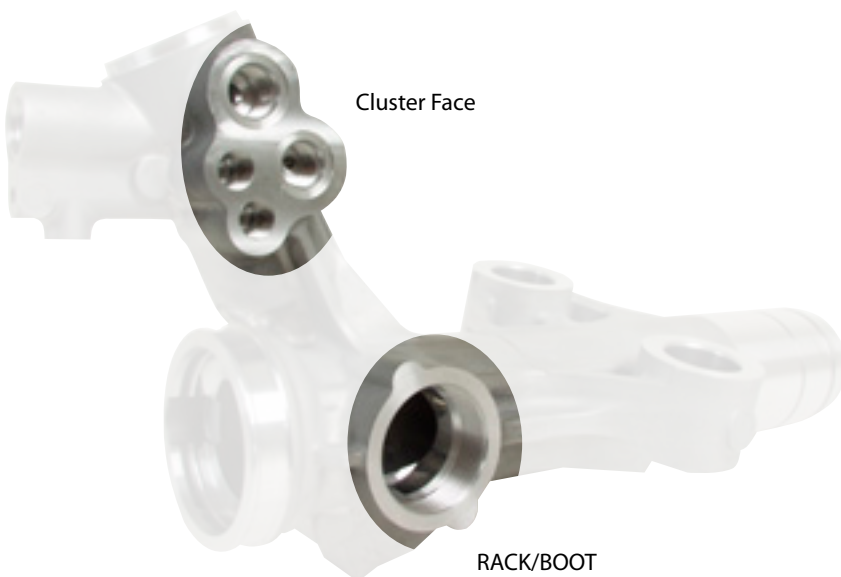

## DESIGN CONCEPT: Combination Tool - Ream + Spotface + Groove

---

This feature specially designed to finish Rack Bore Seat including ID & OD chamfers

This area designed to finish Spotface + ream diameter of Rack Bore with interrupted cut

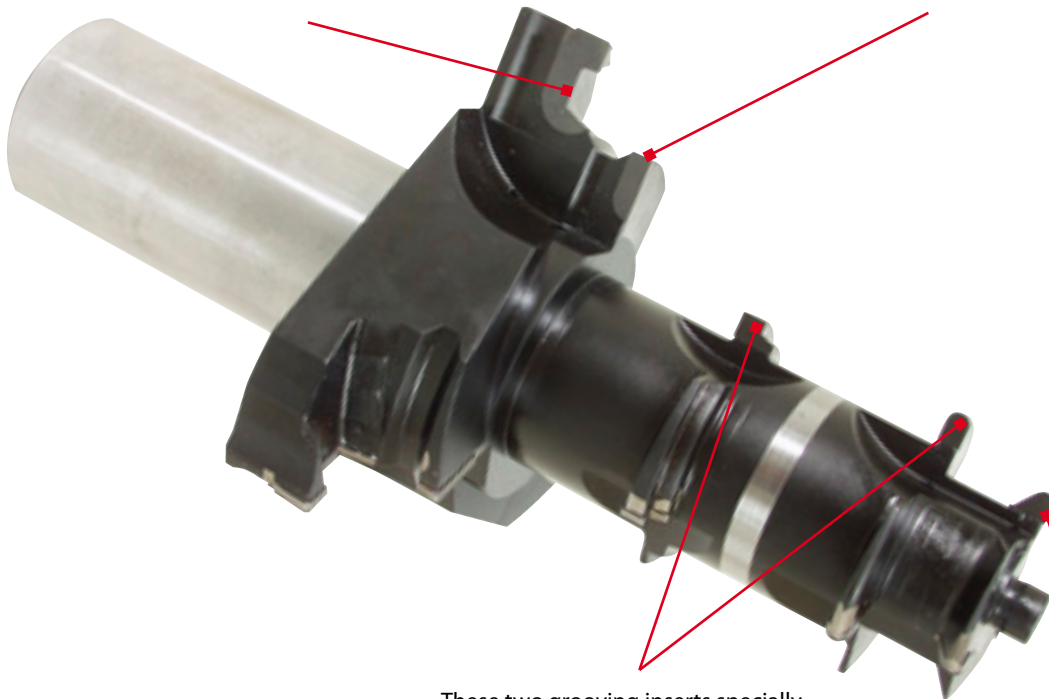

These two grooving inserts specially designed to interpolate grooves on OD in one pass

This grooving insert is specially designed to interpolate + ID groove in Rack Bore

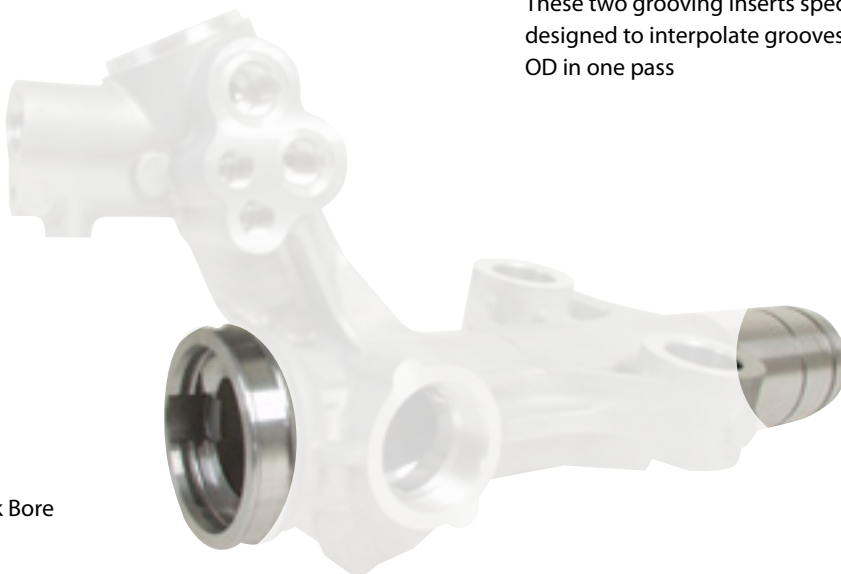

ID Groove

Rack Bore

OD Grooves

## KYOCERA UNIMERCO Tooling A/S

KYOCERA UNIMERCO manufactures, distributes and services tools for machining, as well as measuring equipment for the manufacturing industry. The tooling concept comprises standard and customised tools, RE-NEW® tool maintenance, coating and optimisation guidance. The Danish company was established in 1964 and has product development, production, sales and service in the corporate headquarters, located in Sunds.

The company is part of the KYOCERA UNIMERCO group, founded in Denmark in 1964 and originally named UNIMERCO. In 2011, all activities were taken over by Japan-based KYOCERA. This has created an even stronger company with a larger range of products, a wide network of companies and distributors all over the world, and an ambitious growth plan.

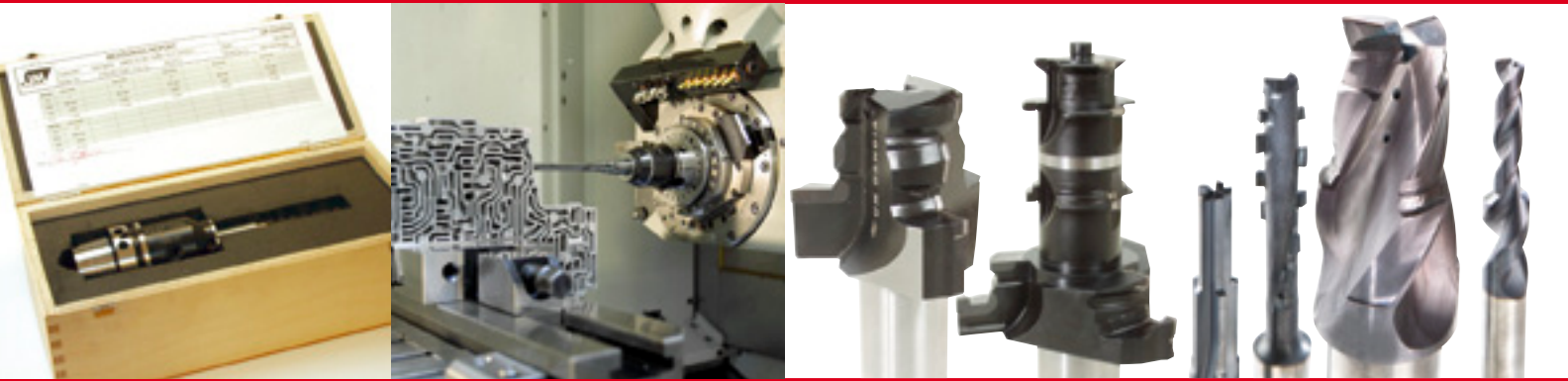

KYOCERA UNIMERCO Tooling A/S

Drejervej 2 · DK-7451 Sunds / Denmark

Tel. +45 97 14 14 11

Fax +45 97 14 14 86

umdk@unimerco.com

www.kyocera-unimerco.com