

PCD tools

UM DANDIA™ tooling solutions for the automotive industry

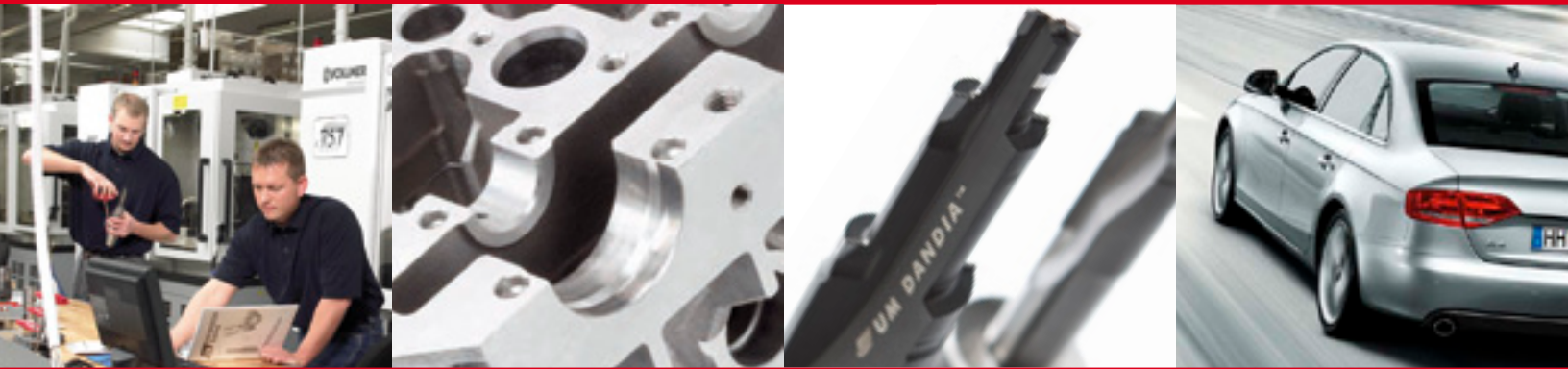

KYOCERA UNIMERCO – your innovative partner

KYOCERA UNIMERCO is specialized in the manufacture of high performance PCD tooling, designed according to customer requirements. Your benefits of working together with us are:

Increased productivity

Tool designs are optimized according to the actual application, which enables you to operate the tools at higher RPM's and feed rates. Increased cutting parameters provide a shorter cycle time, less down-time and thereby a greatly increased productivity.

Increased product quality

The unique guide pad system and the very narrow tolerances of the tools cause less vibrations and thereby less friction. Reduced friction yields a longer tool life, better roundness, more accurate coaxiality and a second-to-none surface quality of holes.

Delivery time

Generally speaking, we are able to deliver PCD tools in 6-8 weeks. In most cases, we offer a design concept for the PCD tooling solution that our sales engineers review. And of course if you require it, we are able to make in-house tests, based on an hourly payment. The result will be documented in a report for you. Thereby we secure that our tools are delivered "ready-to-use".

Professional technical back-up

With highly qualified tooling technicians working in close cooperation with you, we are ready to provide advice not only on the cutting tools but the complete machine environment. In other words, we care about the tool performance until you get the expected output.

Not only regrinding but RE•NEW®

We regrind your tools with the same concern that we use to manufacture new tools. Original tool geometries are also secured in our RE•NEW® process. Additionally, we RE•NEW® other tool brands with very good results - often better than when you received the tool as new.

100% repeatability

But of course not even the tools from KYOCERA UNIMERCO can run forever. Due to a unique internally developed norm-system and a very advanced drawing database, we are able to continuously deliver cutting tools with the exact same geometries throughout all future deliveries, regardless in which of our manufacturing facilities your tools are being produced.



UM DANDIA™ tools

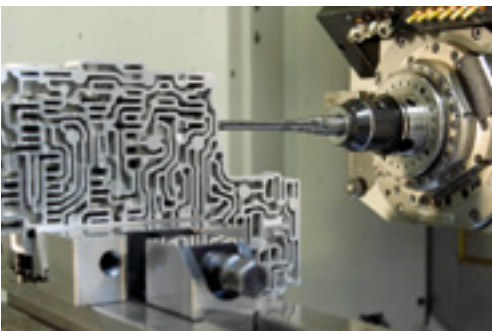

All UM DANDIA™ PCD tools are tipped with top quality PCD material. PCD can be used in all types of non-ferrous materials such as aluminum, zinc, lead, magnesium, brass, bronze, copper, graphite, green carbide, rubber, plastic, fiberglass etc. UM DANDIA™ PCD tools have also proven very successful in machining powdered metal.

Lower total cost

Choosing a PCD tool solution is very often the best way to reduce the cost per produced part. PCD tools offer a number of advantages (tool life, workpiece quality, better process reliability and reduced rejection) which on the overall give lower machining costs and thus the lowest unit price.

Choosing the optimum tool solution

All tools are developed and manufactured utilizing the latest technology. The aim of the tool solution is always to improve the machining situation by increasing productivity, improving surface quality and roundness, prolong tool life etc. Often highly advanced combination tools can reduce the number of tools needed, thus improving production unit costs considerably.

Content of this catalog

This catalog has been divided into the following categories:

- › PCD reamers
- › PCD drills
- › PCD milling tools
- › PCD combination tools.

On the following pages, you will find examples of our wide product range of customized PCD-tools.

We look forward to your inquiry for a customized PCD tooling solution.

PCD drills

PKD HELI-DRILL



.....

› FEATURES

The unique UM DANDIA™ sandwich drill point combined with helical guide pads and flute.

The drill is designed as a one-shot solution and the point geometry can be designed to enter in machined surfaces as well as pre-casted bores. Internal coolant channel design for improved chip evacuation.

› BENEFIT

A high performance one-shot solution, reduced overall cycle time, less tool changes, fewer tools in operation. Maintaining IT9 tolerances up to 10 x d.

› CUTTING DATA EXAMPLE

n = 10000 RPM, fn = 0.4-0.5 mm/rev.

PCD STEP DRILL



.....

› FEATURES

Step drill with the unique point geometry called "Twin Point". Drills in full material with interrupted cuts. Specially designed internal coolant channels ensure optimum chipflow.

› BENEFIT

Lowest possible machining time due to one shot process. Very good tool life and process reliability.

› CUTTING DATA EXAMPLE

n = 6000 RPM, fn = 0.35 mm/rev.

PCD reamers

PCD HELI-REAMER



MQL

› FEATURES

A newly developed reamer design with a unique helical guidepad system, designed for high precision reaming applications. May be used for both wet and MQL machining, operates within extreme roundness, straightness, Ra and Rz values. Furthermore CP and CPK values from 3.16 to as high as 6.7 have been reached.

› BENEFIT

Reduced overall cycle time due to fast cutting parameters and several steps built into "one" tool, extended tool life, less scrapped parts, high consistent part quality, fewer tools necessary.

› CUTTING DATA EXAMPLE

n = 12000 RPM, fn = 0.35-0.50 mm/rev.

PCD VALVE GUIDE REAMER



FERROUS APPLICATIONS

› FEATURES

PCD reamer developed for powdered metal valve guides. Guidepad design allows for extended tool life and size control providing the customer with a very tight diameter range and high Cpk.

› BENEFIT

Unlike designs for bushed transfer lines and machining center applications. Extremely long tool life in addition to excellent size control. Very good seat to guide runout and great throughput. In transfer line applications, tool life is measured in weeks rather than number of parts.

› CUTTING DATA EXAMPLE

n = 2400 RPM, fn = 0.2-0.3 mm/rev.

PCD reamers

PCD STEP REAMER



.....

› FEATURES

Multi-diameter tool allowing for excellent hole size and concentricity between diameters.

› BENEFIT

Unique guidepad geometry allows for excellent roundness and straightness, even in an interrupted cut condition.

› CUTTING DATA EXAMPLE

n = 6000-10000 RPM, fn = 0.25-0.40 mm/rev.

PCD STEP REAMER



.....

› FEATURES

Special design for injection bore. The fluting and coolant geometry layout is specifically designed for this application. The tool enables high precision cutting with extreme fast cutting parameters (in several cases double-up in comparison to the "normal" market features).

› BENEFIT

Extreme cutting parameters shorten cycle time thus reducing overall costs. Also, the long tool life that comes from UM DANDIA PCD tooling coupled with the possibility of RE-NEW® further reduces the total tooling costs.

› CUTTING DATA EXAMPLE

n = 10000 RPM, fn = 0.3 mm/rev.

PCD STEP REAMER



.....

› FEATURES

Monoblock reamer with uneven number of inserts allowing for excellent hole size and surface quality. The integrated spindle adapter and multiple step diameters ensure good concentricity between diameters. Internal coolant channel design for improved chip evacuation.

› BENEFIT

Reduced overall costs, due to reduction in cycle time provided by the very high cutting parameters. The very long tool life means that fewer tools are needed – also due to the possibility to RE•NEW® the tools.

› CUTTING DATA EXAMPLE

n = 5000-7000 RPM, fn = 0.3-0.5 mm/.

PCD STEP/PROFILE REAMER



.....

› FEATURES

Combining reamer and profile geometry on the PCD inserts, this multi-purpose PCD tool is able to cut three different difficult features in one PCD tool.

Fluting and cutting geometries developed specifically for this application.

› BENEFIT

This combination reamer enables reduced overall cycle time due to fewer operations and increased cutting parameters.

› CUTTING DATA EXAMPLE

n = 8000-15000 RPM, fn = 0.3-0.5 mm/rev.

PCD combination tools

PCD STEP REAMER/MILL



.....

► FEATURES

A specially designed PCD insert and flute geometry combining several operations in one tool. Insures a vibration free finishing of all valve bore diameters in one pass, creates different surface roughness values within a specified range and a T-groove geometry.

► BENEFIT

Reduced overall cycle time with the multi tasking tool design due to reduction of tool changes and number of tools necessary.

► CUTTING DATA EXAMPLE

n = 3000 RPM, fn = 0.2-0.3 mm/rev.

PCD STEP DRILL/REAMER



.....

► FEATURES

A special 2-fluted tool design for the shrink fit holder system. First step is drilling in solid material whereas the remaining steps are reaming pre-casted material. Internal coolant channel design for improved chip evacuation.

► BENEFIT

One-shot solution, reduced overall cycle time, less tool changes, fewer tools in operation.

► CUTTING DATA EXAMPLE

n = 6500 RPM, fn = 0.3-0.4 mm/rev.

PCD REIMER/COUNTERSTINK TOOL



► FEATURES

Special PCD tool design in the flute opening, coolant placement and guidepad geometry. This tool is available in either a combination tool, with solid carbide tool body for the PCD reamer and steel body for the PCD bushing, or in a one piece construction.

► BENEFIT

High cutting parameters yield reduced overall costs due to reduction in cycle time. Furthermore, less number of total tools are required because of the long tool life coupled with our RW•NEW process.

► CUTTING DATA EXAMPLE

n = 8000 - 15000 RPM, fn = 0.25 - 08 mm/rev.

OUT-BORE PCD REAMER, ADJUSTABLE

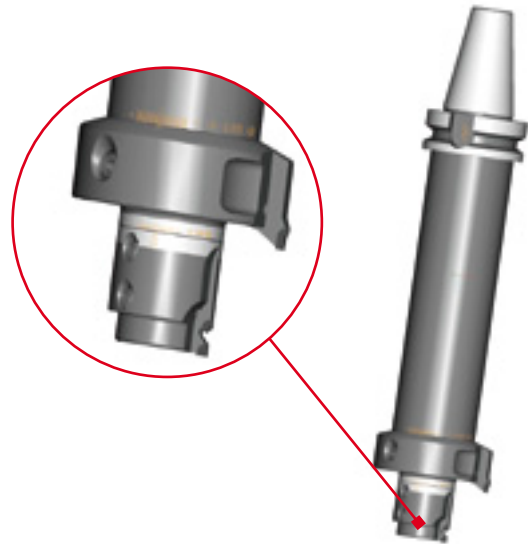

► FEATURES

Single flute, out-bore, multi diameter PCD tool. The different diameters can be adjusted separately fast and easy due to the unique UM DANDIA™ design. The tool holder / spindle adapter allows for customized design.

► BENEFIT

Very accurate hole quality and production reliability. Extremely easy to run in and reduced overall cycle time due to the separate diameter adjustability.

► CUTTING DATA EXAMPLE

n = 2000 - 4000 RPM, fn = 0.1-0.2 mm/rev.

PCD combination tools

PCD OUT-BORE TOOL



.....

› FEATURES

Single flute, out-bore, multi diameter PCD tool. The design towards the PCD cutting edges enables the tool to operate both the front and rear end of the work piece in one set-up. The out-bore reamer is exchangeable and adjustable.

› BENEFIT

Reduced overall cycle time with the multi tasking tool design due to reduction of tool changes and number of tools necessary. Better hole quality on the component machined.

› CUTTING DATA EXAMPLE

$n = 3000 \text{ RPM}$, $f_n = 0.15 \text{ mm/rev}$.

PCD OUT-BORE TOOL



.....

› FEATURES

Single flute, out-bore, multi diameter PCD tool. Special design with specific flute geometry for improved chip evacuation. The design towards the PCD cutting edges enables the tool to operate both the front and rear end of the work piece in one set-up.

› BENEFIT

Reduced overall cycle time with the multi tasking tool design due to reduction of tool changes and number of tools necessary. Better hole quality on the component machined.

› CUTTING DATA EXAMPLE

$n = 3000 \text{ RPM}$, $f_n = 0.15 \text{ mm/rev}$.

PCD PROFILE TOOL

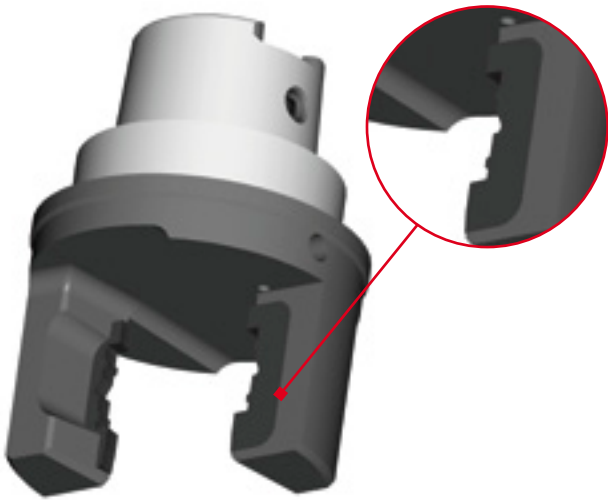

.....

› FEATURES

A uniquely designed PCD profile tool for machining parts in soft aluminum, AlSi1CuMg3. Cutting edge geometry developed to cut dry without lubrication and using only air to cool the process.

› BENEFIT

High production reliability and productivity.

› CUTTING DATA EXAMPLE

n = 8000 RPM, fn = 0.38 mm/rev.

PCD HOLLOW REAMER



.....

› FEATURES

A specially designed PCD hollow reamer with adjustable and replaceable cartridges. These PCD cartridges can be customized according to application and part requirements. E.g. to create different surface roughness values within a specified range.

The tool can ream ID inner diameter and ad outer diameter as well ad OD in the same pass.

› BENEFIT

Reduced overall cycle time with the multi tasking tool design due to reduction of tool changes and number of tools necessary.

› CUTTING DATA EXAMPLE

n = 4000 RPM, fn = 0.2-0.3 mm/rev.

PCD mills

PCD END MILL



► FEATURES

Standardized UM DANDIA™ PCD mill. Internal coolant channel and solid carbide tool body ensures optimal performance and tool life.

The PCD insert geometry is designed to minimize cutting forces and create a good surface quality with a high stock removal rate.

► BENEFIT

Reduced overall costs, due to reduction in cycle time provided by the extreme cutting parameters. The very long tool life means decreased purchase of new tools and the possibility of RE-NEW® of the tools.

► CUTTING DATA EXAMPLE

Finishing: $n = 15000-25000$ RPM, $f_n = 0.1-0.3$ mm/rev.
Roughing: $n = 12000-25000$ RPM, $f_n = 0.2-0.5$ mm/rev.

PCD MULTI-MILL



► FEATURES

A special designed milling cutter with coolant outlets for each PCD insert allowing for both face and side milling at very high cutting parameters.

► BENEFIT

Reduced overall cycle time due to fast cutting parameters and a very long tool life, furthermore this design may be used for both rough and finish milling.

► CUTTING DATA EXAMPLE

$n = 15000-18000$ RPM, $f_n = 0.2-0.3$ mm/rev.

PCD BALL NOSE CUTTER



► FEATURES

Standardized UM DANDIA™ ball nose PCD mill. Internal coolant channel and solid carbide tool body ensures optimal performance and tool life.

The PCD insert geometry is designed to minimize cutting forces and create a good surface quality with a high stock removal rate.

► BENEFIT

Reduced overall costs, due to reduction in cycle time provided by the extreme cutting parameters. The very long tool life means decreased purchase of new tools and the possibility of RE•NEW® of the tools.

► CUTTING DATA EXAMPLE

Fertigung: n = 15000 RPM, fn = 0.1-0.2 mm/rev.
Schruppfräsen: n = 12000-15000 RPM,
fn = 0.15-0.30 mm/rev.

PCD BALL NOSE CUTTER



► FEATURES

Customized UM DANDIA™ ball nose PCD mill with integrated spindle adapter. Cutting profile is divided into several tips. Internal coolant channels.

► BENEFIT

Internal coolant channel and divided insert design ensure optimal performance and minimize the cutting forces.

► CUTTING DATA EXAMPLE

Fertigung: n = 10000-15000 RPM,
fn = 0.5-0.8 mm/rev.

PCD mills

PCD SHELL END MILL/FACE MILL



.....

► FEATURES

Fixed pocket milling cutter capable of face milling face and side milling low or high-silicon aluminum components. Tool body can be extended or reduced in length depending on reach or possible interference. Diameter can be increased or decreased based on radius requirements or hard to reach features.

A high number of tips can be applied compared to traditional cutters with indexable inserts

► BENEFIT

Excellent surface finish and cycle times. PCD's can be shimmed outward several times for inexpensive RE•NEW®.

► CUTTING DATA EXAMPLE

$n = 10000-15000$ RPM, $f_n = 0.2-2.0$ mm/rev. depending on number of tips

PCD MILLING CUTTER

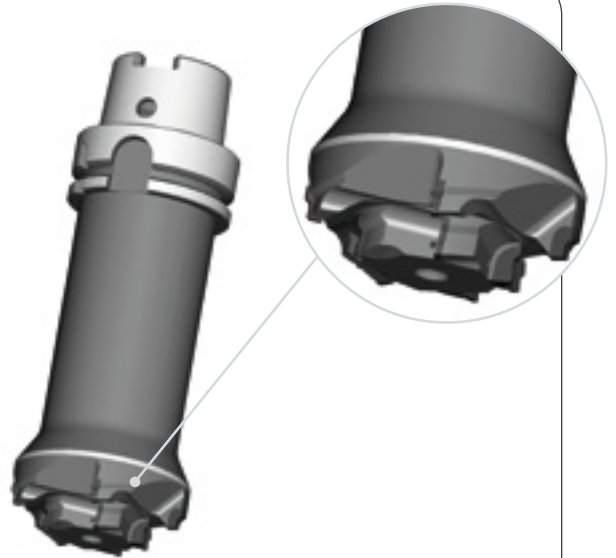

.....

► FEATURES

Multi-feature milling tool produces many intricate features in one milling pass using either through-tool coolant or MQL.

► BENEFIT

Reduced overall cycle time with the multi tasking tool design due to reduction of tool changes and number of tools necessary.

► CUTTING DATA EXAMPLE

$n = 15000$ RPM, $f_n = 0.5$ mm/rev.

PCD MILLING CUTTER



.....

› FEATURES

Inserts divided to have optimum cutting geometry on the entire profile. Shear and axial angle technology combined with a unique transition between the inserts ensure superior surface quality on the work piece and overall profile tolerances within $\pm 0,01$.

› BENEFIT

Machining complex geometry in one pass maintaining very fine profile tolerances.

Reducing overall cycle time. Reduction of tool changes and number of tools necessary.

› CUTTING DATA EXAMPLE

n = 10000 RPM fn = 0.2 mm/rev.

PCD MILLING CUTTER

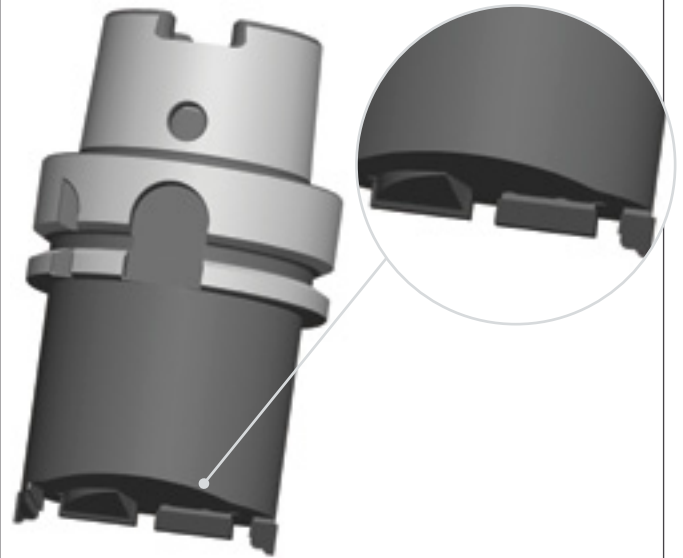

.....

› FEATURES

A uniquely designed PCD profile milling tool for machining part in soft aluminum, AISi1CuMg3.

Cutting edge geometry developed to cut dry without lubrication and using only air to cool the process.

› BENEFIT

High production reliability and productivity.

› CUTTING DATA EXAMPLE

n = 8000 RPM, fn = 0.4 mm/rev.

KYOCERA UNIMERCO Tooling Inc.

KYOCERA UNIMERCO manufactures, distributes and services tools for machining, primarily for the metal, automotive, aerospace, fluid power and woodworking industries. The tooling concept comprises standard and customized tools, RE-NEW® tool maintenance, coating and optimization guidance.

The American company was established in 1995. Today, the company has product development, production, sales and administration in Saline, Michigan. The company is part of the KYOCERA UNIMERCO group, founded in Denmark in 1964 and originally named UNIMERCO. In 2011, all activities were acquired by KYOCERA. This has created an even stronger company with a larger range of products, a wide network of companies and distributors all over the world, and an ambitious growth plan.

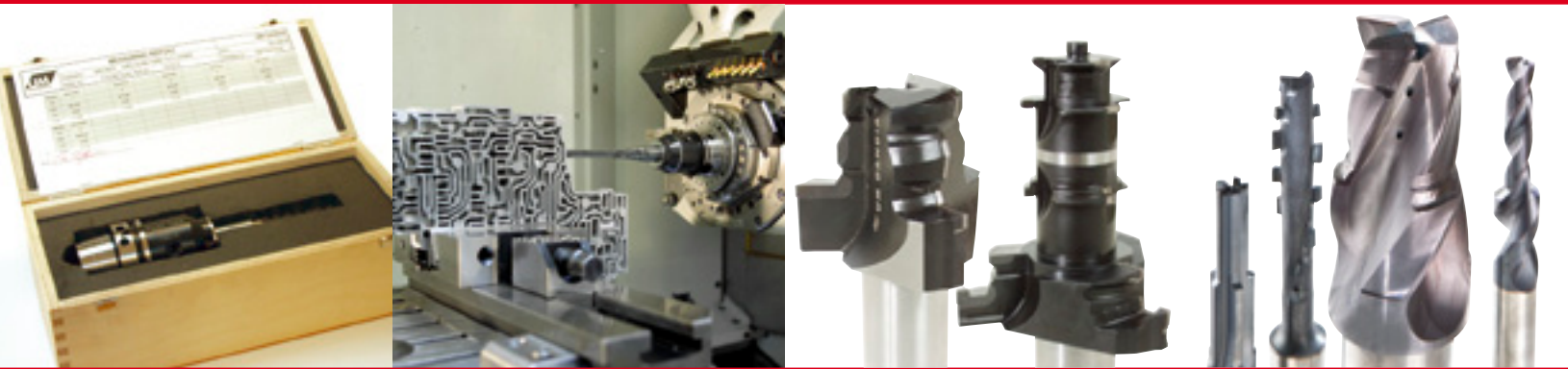

KYOCERA UNIMERCO Tooling Inc.

6620 State Road · Saline · MI 48176

Ph +1 734 944 4433

Fax +1 734 429 5177

ummi@unimerco.com