

# Cutting tools & services

for the woodworking industry





# FROM WOOD TO...



FURNITURE

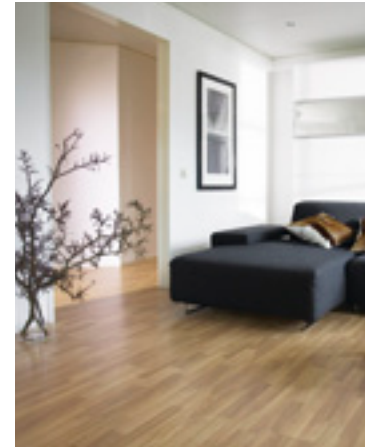

FLOORING

No matter whether you produce furniture, kitchens, joinery components, floors or windows - in chipboard, MDF or solid wood - you need the best possible tooling solution and professional guidance on how to use it. We offer a wide range of high quality tools for almost all segments and applications within the furniture and woodworking industries.

All tools are manufactured according to EN847.

In most areas, more than one quality level can be supplied. HP is our category of high performance, optimum quality tools, where SP will be the best choice for less demanding applications. Furthermore, many tools with different carbide grades can be supplied in order to suit the various workpiece materials used.

Please read this catalog to learn more about the KYOCERA UNIMERCO cutting tool range and services for the woodworking industry.



KITCHEN

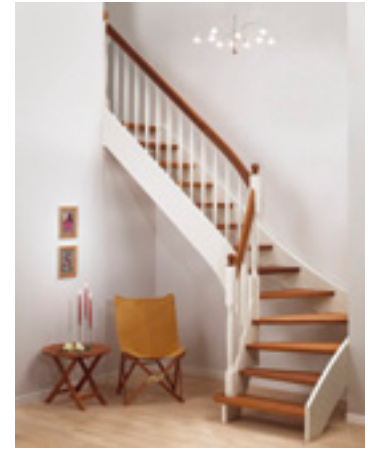

JOINERY



MOLDING



WINDOWS



## Standard and special cutting tools

A complete range of standard tools is at your disposal. Most common tools will be in stock. If you have special requirements, which can not be solved with standard tools, a special design may be produced to suit your needs. Improved tool designs and concepts are constantly being developed in order to give you the latest cutting technology.



## Optimisation of production

You can also benefit from our many years of experience with tooling solutions for the woodworking industries. Through analyzes and optimisation of the production key processes, we can offer you guidance on how to optimize your production. This will help you to secure that your production operates at the lowest possible cost and with optimum performance.



## RE•NEW® – Secure tool transport

All products for RE•NEW® are taken care of by KYOCERA UNIMERCO with a complete service package, which, in several countries, also includes a UNI•SERVICE™ pick-up and delivery service. Where UNI•SERVICE™ is not available, tool transport is carried out in cooperation with partners. In this way, you can concentrate your efforts on your main business area.



## RE•NEW® – Optimum tool maintenance

KYOCERA UNIMERCO tools as well as other tool brands can be renewed using the latest technology in tool maintenance and regrinding. The RE•NEW® services include washing, inspection, re-grinding/re-tipping and final inspection before sending. A performance guarantee is offered on all RE•NEW® items. Where suitable, tools for RE•NEW® will also be re-coated.

# WE OFFER YOU...

**Spirals** ..... 6 - 7

Standard routers › Coated routers › Special routers

**Drills** ..... 8 - 9

Standard drills › Coated drills

**DP Tools**..... 10 - 11

Standard DP › Special DP tooling › DP molding tools › DP bore tools

**Profiling tools**..... 12 - 13

Profiling systems, standard › 3-P tools › UM-Profile combination tools

**Tool holding systems**..... 14 - 15

Holders for shank type tools › Holders for bore tools › Aggregate heads

**Saw blades** ..... 16 - 17

Standard and special sawblades

**Knives** ..... 18 - 19

**Planing and molding** ..... 20 - 21

Planer heads and knives › Serrated heads › Hydroblocks › Helical heads ›  
Fingerjoint cutters › ISO planer head › Rotary tools › Quick-Set tools

**Window tooling** ..... 22 - 23

# SOLID CARBIDE SPIRALS

Improved cutting quality – long tool life

KYOCERA UNIMERCO offers a wide selection of standard cutters for most applications. Our standard program ranges in size from diameters 6-25 mm with various cut lengths depending on the diameter. We deliver positive and negative spirals as well as left or right hand rotations. Customized solutions for special applications are also available, ensuring the optimum tooling solution according to our customers' special requirements.

## Materials

- › Hardwood
- › Softwood
- › Board materials
- › Certain plastics
- › Composite stacks
- › Trespa

## Customer advantages

- › Sharp cutting edge without microchips ensuring uniform geometry, which results in an improved cutting quality, work piece surface and operation.
- › High wear resistance which allows for more regrindings and therefore longer tool life.
- › Fewer vibrations and less machine/engine wear. This gives a long durability, which means fewer tool investments and less machine repair and maintenance.
- › Spirals adjusted to the material machined, which gives an optimum cutting quality and less finishing.

# Standard routers



HP + SP

Spiral roughing cutters, solid carbide

Available as 2- or 3-fluted, with chip breaking form and end cutting. Available as up cut or down cut in L/H and R/H rotations.

Item no.	Diameter
784400 → 784445	8-25 mm



HP + SP

Spiral finishing cutters, solid carbide

Available as 2- or 3-fluted, for finishing operations giving high quality of finish. Available as up-cut or down-cut, L/H and R/H rotations available in various dimensions.

Item no.	Diameter
784902 → 784965	6-25 mm



HP

Lock-case cutters, solid carbide

For routing of lock housings and face plates, depth up to 110 mm. Up-cut spiral for chip removal.

Item no.	Diameter
785015 → 785025	10-18 mm

# Coated routers



HP + SP

Up/down (compression) spirals, solid carbide

For grooving, sizing and jointing. Up/down shear gives clean-cut edges top and bottom.

Item no.	Diameter
785041 → 705049	8-20 mm



2-3 times increased life time

Up/down (compression) spirals, solid carbide

Coated cutters are used in material, which relatively quickly wears out standard cutters. An example is workpieces with a combination of wood and steel/aluminum.

# Special routers



Up/down (compression) spirals, solid carbide

A wide variety of special designs, for example cutters with through points. Special diameters and cut lengths can be supplied.

# DRILLS

Supplied for all purposes

Drills and cylinder bores are supplied for all purposes. Dowel drills are supplied in a standard and high-performance quality with diameters 4-16 mm. Through-holes are supplied in a standard and high-performance quality with diameters 4-12 mm. Cylinder bore bits are supplied in a high-performance quality with diameters 12-90 mm.

Special drills can be supplied upon request. As an extra service, drills can be coated with a special coating that increases tool life considerably.

## Materials

- › Hardwood
- › Softwood
- › Board materials
- › Certain plastics
- › Composite stacks
- › Trespa

# Standard drills



**HP + SP Carbide-tipped dowel drills with standard point**

For drilling of blind holes, giving clean entrance hole with good chip removal. Carbide-tipped for longer tool life.

Item no.	Diameter
1807.xx → 1817.xx	4-16 mm



**HP Carbide-tipped dowel drills with UM special point**

For panel processing and solid wood along the grain, to give a perfect edge of the hole. Carbide-tipped for longer tool life.

Item no.	Diameter
1810.xx → 1810.xx	4-12 mm



**HP Solid Carbide dowel drills with UM special point**

For panel processing. Gives a perfect edge of the holes. Solid carbide for longer tool life and more regrinds.

Item no.	Diameter
1810.xx → 1810.xx	4-12 mm



**HP + SP Carbide-tipped through-hole drills**

For through holes on boring machines, giving clean entrance and exit holes. Carbide-tipped for increased tool life.

Item no.	Diameter
1807.xxx → 1810-1811.xxx	4-12 mm



**HP Cylinder bore bits, carbide-tipped, with or without centering point**

For hinge holes/cam holes etc. Spurs give excellent hole quality.

Item no.	Diameter
1808.xxx 1812.xxx → 1813.xxx 1817.xxx	12-90 mm

# Special routers



For special applications, coated drills are an option. Most often, coating is used on solid carbide drills in order to increase tool life.

# DP TOOLING

## Optimized chip flow

KYOCERA UNIMERCO manufactures and supplies DP tools for all applications in the wood-working industry. DP tools were formerly known as PCD/diamond tools.

Besides sawblades, scoring blades, knives and drills with DP tips, KYOCERA UNIMERCO also offers DP routers that give longer tool life than traditional carbide cutters. High performance DP router bits have higher tips allowing the tools to be reground several times. Furthermore, KYOCERA UNIMERCO offers special DP tooling and a range of profile tools that are designed to give optimum chip flow and wear resistance due to coated tool bodies and quality erosion techniques.

Finally, it is a pleasure to offer you a newly developed DP hogger with unique cutting geometries which gives an unrivaled surface and an excellent finish.

### Materials

- › MDF / MFC
- › Board materials,  
laminated/veneered or raw
- › Certain plastics
- › Hardwoods

# Standard DP



## SP DP router bits

Economical tools for processing of MDF and board materials. Carbide plunge tip. Up/down shear for optimum cut quality.

Item no.	Diameter
199208 → 199366	10-20 mm



Feed rates up to 35 m/min

## HP DP router bits

High performance tool for sizing at increased feed rates up to 35 m/min. Up/down shear ensures good finish top and bottom of board

Item no.	Diameter
199385 → 199415	20-48 mm



## UM First DP hogger

New design standard DP hogger, extended tool life and improved cut quality.

Item no.	Diameter
198862 - Left 198863 - Right	250 mm

# Special DP tooling



KYOCERA UNIMERCO supplies and manufactures profile routers to specific customer profiles for kitchens/bedrooms/bathrooms etc. Profiles can be matched to existing profiles from sample work pieces or from customer drawings.

# DP molding tools



Tooling for high-speed molding to suit the latest machinery, including the Powerlock system.

# DP bore tools



Supply and manufacture of DP bore tools for edgebanding milling blocks, flooring tools and saw blades, hydro mounted if required.

# UM PROFILE AND GROOVING CUTTERS

## High rotational and cutting speed

UM Profile is a flexible system with changeable 2 mm knives that gives an improved stability and permits more regrinds. Available as shank type tooling for use on CNC machines or as bore tools for use on molders. Blocks can also be supplied with deflector plates for use on manual feed machines.

Another possibility is the UM 3-P system, which is a single-profile system without support plate and wedge, designed for high speed machining.

### Materials

- › Hardwood
- › Softwood
- › Board materials
- › Certain plastics
- › Composite stacks
- › Trespa

### Customer advantages - UM profile

- › UM Profile can be used at high rotational speed which is unique compared to other systems. Optimum cutting speed is up to 81 m/sec. That gives the possibility of higher productivity, quality and cutting performance.
- › A multiple profiling tool which enables many different profiles in the same tool body.
- › Less vibration and less machine/engine wear. This ensures long durability, which means fewer tool investments and less machine repair and maintenance.
- › UM Profile equals high security. The UM Profile system follows the European security norm EN 847.

# Profiling systems, standard



Tools with bore

Item no.	Diameter
752000 → 752208	125-235 mm



Shank type tools

Item no.	Diameter
752011 → 752443	60-125 mm



Panel raising cutters

Item no.	Diameter
752080 → 752298	150-200 mm

## 3-P tools



Ornamental grooving cutters - Profivit

Item no.	N max from
751825 → 751836	18000-24000



Manual feed tools

Item no.	Diameter
752000 → 7522xx	125-150 mm



For high speed operations, single-profile tools without support knives are manufactured. This gives more stability and thereby longer tool life.



Special tool combining edge and ornamental operations into one tool in order to minimize number of tool changes and increase output.



Special tool combining edge and ornamental operations into one tool in order to minimize number of tool changes and increase output.



High performance tool with profiling and knives for ornamental grooves in the same tool to increase tool life and reduce number of tool changes.

# TOOL HOLDING SYSTEM

Better balance – longer lifetime

In general, the different tool holding systems are used for CNC and other machine types in the woodworking industry for different applications.

SP and HP collet chucks are very flexible and can be used with most machines. A broad diameter variance of precision collets can be used for this tool type. UM Tribos has a very high precision, giving high tolerances. This also gives the holding tool a long tool life and a lower spindle weight resulting in a better balance and longer spindle lifetime.

Our tool holding range also includes an extensive number of holders for tools with bore and hoppers.

# Holders for shank type tools



## SP Collet chucks

Bearing in locknut means there is no need for L/H and R/H versions.



## Adapters, arbors etc.

Available with cones to suit most machines: Masterwood, SCM, Homag etc.



## XP Tribos system and chucks

Tribos system gives full benefit of performance tooling due to minimal run-out compared to traditional systems.

Item no.	Clamping diameter	Revolution rate
182003 → 182090	3-30 mm	max. 24000 rpm

Item no.
182101 → 182442

Item no.	Clamping diameter	Revolution rate
182003 → 182090	3-30 mm	max. 24000 rpm

# Holders for bore tools    Aggregate heads



## XP Hydro chucks

Available with cones to suit most machines: Masterwood, SCM, Homag etc.

Item no.
182203 → 182379



For tools with bore, sawblades and hoppers, different type of tool holders can be supplied. The range includes standard bushes, hydro tools and quick exchange systems.



In order to increase flexibility on CNC machines, aggregate heads can be supplied.

# CIRCULAR SAW BLADES

## Reducing customer production costs

KYOCERA UNIMERCO supplies a wide range of circular saw blades in different quality levels for the woodworking industries. All with a high performance aimed at reducing your production costs.

Every saw blade can be delivered with different tooth types that fit exactly to the desired application.

Performance can be further enhanced by our range of coatings (C5 or C7 PLUS™), each one designed to reduce the number of blade changes and thereby reducing machine downtime.



**freud**®

# Standard and special sawblades

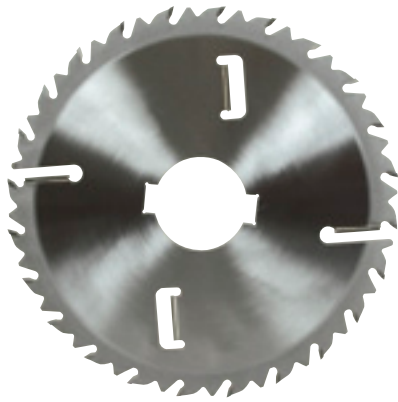

## HP + SP Multi-rip saw blades

Wiper slots ensure good chip removal in wet wood.

Item no.	Diameter
20150.xx → 20500.xx	150-500 mm



## XP + HP + SP Crosscut/sizing saw blades

For coarse sizing cuts.

Item no.	Diameter
21100.xx → 22700.xx	4-12 mm

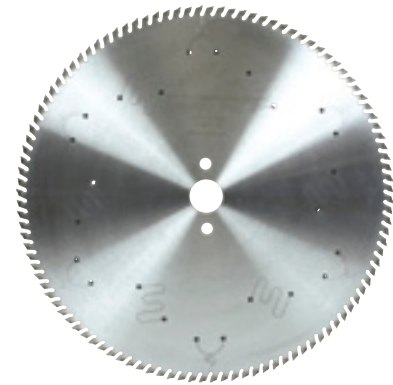

## XP + HP + SP Panel sizing saw blades

Different tooth form and geometry to suit application.

Item no.	Diameter
24250.xx → 24730.xx	250-730 mm



## XP + HP + SP Scoring saw blades

For use on machines with scoring device.

Item no.	Diameter
25080.xx → 25340.xx	80-340 mm



## HP + SP Clipping saw blades

For use on edgbanding machines.

Item no.	Diameter
26090.xx → 26195.xx	90-195 mm



## XP + HP + SP Non-ferrous metal saw blades

Used for aluminum cutting.

Item no.	Diameter
28220.xx → 28730.xx	220-730 mm

# KNIVES

## Continuous cutting performance

KYOCERA UNIMERCO stocks a comprehensive range of standard, radius, groove and profile knives for the most common tooling systems in the woodworking industry – furniture, kitchen, window and door production. Furthermore, we profile knives for other systems on the basis of wooden samples or sample knives.

### Knives for several tooling systems such as:

- › Rekord
- › Freud
- › Leitz
- › Stark
- › Öertli

### Customer advantages - UM profile

- › UM knives make it possible to maintain the same tool characteristics and thereby continuous cutting performance.
- › UM knives make it possible to change between different carbide grades depending on the material being cut.
- › UM knives provide good value for money.



### HP + SP Straight reversible knives

Straight turnover knives, available in different grades to suit application. DP tipped knives are also available.

Item no.	Width range
1890xx,xx → 1896xx,xx	7,5-120 mm

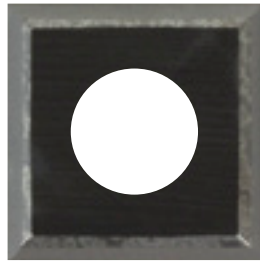

### HP + SP Scoring knives

Scoring knives with 2, 3 or 4 cutting edges depending on cutterblock.

Item no.	Width range
1890xx,xx → 1892xx,xx	4-12 mm



### HP + SP Super profiles

Knives to suit the Super profile system, profiled to suit customer requirements.

Item no.	Width range
191930,xx →	250-730 mm



### HP + SP UM profiles

Profile knives to suit the UNIMERCO UM-Profile system, available in different grades and with or without mirror finish.

Item no.	Width range
191740,xx →	40-120 mm



### HP + SP Radius/grooving knives

Grooving knives to suit most systems.

Item no.	Width range



### HP Knives for other systems

Knives available to suit most systems including Freud, Leitz, Oertli, Leuco Zuani, Rekord.

Item no.	Width range

UM Quality	Hardness	Tensile strength	Material type					
			HDF	MDF	CHIPBOARD	HARDWOOD	SOFTWOOD	GLUE BOARD
UM01	2.550	3.200	++++	++++	+++	+	-	-
UM02	2.350	3.500	++++	++++	+++	+	-	-
UM3	2.020	3.300	++++	++++	++	+	-	-
UM4	2.150	2.400	+++	++++	++++	+	++	-
UM5	1.760	2.350	++	++	+++	+++	+++	+++
UM6	2.040	2.450	++	+++	++	++++	++++	+++
UM7	1.950	2.500	+++	++++	++++	+	-	-
UM8	1.750	3.400	-	+	-	+++	++	++++
UM15	1.640	2.300	-	++	++	++	+	+
UM20	1.600	2.500	-	+	+	++	++	++
UM20	1.650	3.600	-	-	+	+++	+++	++
UM30	1.470	2.700	-	-	-	++	++	+
UM40	1.400	2.900	-	-	-	+	++	+
UM60	1.350	3.800	-	-	-	+++	++++	+
UM70	1.400	3.800	-	-	-	++++	++++	+

# PLANING, MOLDING AND GROOVING SYSTEM

## Optimum solution for finishing

The tooling range for planing, molding and grooving includes hydroblocks, fingerjoint cutters and helical planer heads. It also includes Quickset profiling tools, which are designed for high speed molding operations.

For finishing on molding machines, planing machines and thicknessing machines, the Tersa system is the perfect solution. The decisive advantage of the Tersa system is the user friendliness. Knives can be mounted in the planing head without the use of screws or keys, and they are fixed in the right position by means of a specially made wedge. The centrifugal force presses the wedge outward towards the knife.

To replace the knife, the wedge must be pushed back, and the knives can be replaced without the use of any other tools.



Knives for the Tersa system are available in 7 different grades:

Knife quality	Description	Application
HW	Standard HW knife in Micrograin quality	For hardwoods and abrasive material
HW 10° negative	HW knife in Micrograin quality with new geometry.	For American oak and other types of hardwood
HS	Standard HS knife	For softwood
HS M42+	HS knife with same geometry as standard HW knives and in a better HS quality.	For softwood
HS coated	All of the above mentioned HS knives can be supplied with a special coating.	For the same types of wood as HS and for abrasive material as well as wood with gluelines.
Chrome	Standard Chrome knife, which is the cheaper alternative to HS and HW.	For softwood
Chrome negative	Standard Chrom-knife, which for a surcharge can get a geometry like HS - and HW - Negative	For birch, spruce and pine

Only original Tersa knives are supplied by Unimerco, as the use of non-original knives can damage the planer heads.

# Tersa planer heads and knives



Tersa R2000 cutters, standard

Item no.	Diameter
198100 → 198410	100-140 mm



Shank type tools

Item no.	Diameter
193300 → 193750	100-200 mm



Panel raising cutters

Item no.	Diameter
184540 → 184562	100-260 mm

## Hydroblocks



Large range of hydroblocks can be supplied. Grease nipples will be placed according to your wishes.

## Helical heads



Several types of helical planing cutters can be supplied. Design for roughing or finishing operations is available.

## Fingerjoint cutters



Fingerjoint cutters (brazed or exchangeable knives) are also part of the range. Coated solutions are supplied for longer tool life. Most common types are in stock.

## ISO planer head



The new Freud ISO planer heads enable you to maintain the same diameter even after various sharpenings

## Rotary tools



The Rotary tool solution revolutionizes the process of manufacturing ornamental designs such as balusters for internal stairs or external decking, newel caps, newel posts, table legs etc.

## Quick-Set tools



The Quick-Set tool solution is designed for high speed operations in the molding industry. All common profiles can be manufactured. Biggest advantage of this tool solution is the easy adjustability. Carbide is used for longer tool life.

# WINDOW TOOLING

## Continuous cutting performance

For window projects, KYOCERA UNIMERCO offers the “total package” – technical competencies, standard and customized products and education. This ensures that our customers have the most rational production.

KYOCERA UNIMERCO is involved world wide in window projects when it comes to selecting the correct cutting tool for a specified production. Together with our partner within window tooling, Freud, we have the knowledge and experience that our customers benefit from. Many of our window and door customers have experienced improved tool life and cutting quality as well as a very accurate performance.

KYOCERA UNIMERCO supplies a large range of inserts, screws, wedges and profiled inserts that are designed exactly to our customers' requirements.

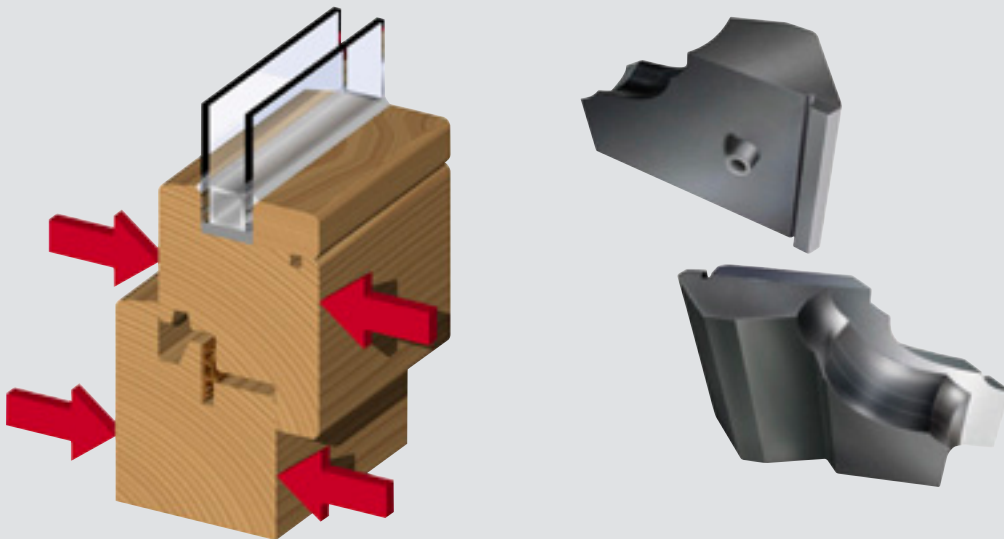

# Freud supplied by KYOCERA UNIMERCO



**freud**<sup>®</sup>

## KYOCERA UNIMERCO Tooling Inc.

KYOCERA UNIMERCO manufactures, distributes and services tools for machining, primarily for the metal, automotive, aerospace, fluid power and woodworking industries. The tooling concept comprises standard and customized tools, RE•NEW® tool maintenance, coating and optimization guidance.

The American company was established in 1995. Today, the company has product development, production, sales and administration in Saline, Michigan. The company is part of the KYOCERA UNIMERCO group, founded in Denmark in 1964 and originally named UNIMERCO. In 2011, all activities were acquired by KYOCERA. This has created an even stronger company with a larger range of products, a wide network of companies and distributors all over the world, and an ambitious growth plan.



KYOCERA UNIMERCO Tooling Inc.

6620 State Road · Saline · MI 48176

Ph +1 734 944 4433

Fax +1 734 429 5177

ummi@unimerco.com